

► **Code Number**

3772611

► **Description**

Exposed, Sensor Activated Sloan® Model Urinal Flushometer for ¾" top spud urinals.

► **Specifications**

Quiet, Exposed, Diaphragm Type, Chrome Plated Urinal Flushometer for either left or right hand supply with the following features:

- Vacuum Breaker with Flush Connection
- Sweat Solder Adapter with Cover Tube and Cast Wall Flange
- ¾" I.P.S. Screwdriver Bak-Chek® Angle Stop with Vandal Resistant Stop Cap
- Spud Coupling and Spud Flange for ¾" Top Spud
- No External Volume Adjustment to Ensure Water Conservation
- OPTIMA® EL-1500 Self-Adaptive Infrared Sensor with Indicator Light

Valve Body, Cover, Tailpiece and Control Stop shall be in conformance with ASTM Alloy Classification for Semi-Red Brass. Valve shall be in compliance with the applicable sections of ASSE 1037 and ANSI/ASME 112.19.2.

- Diaphragm, Stop Seat and Vacuum Breaker to be molded from PERMEX® rubber compound for Chloramine resistance

► **Accessories (specify separately)**

- Transformer (120 VAC/24 VAC 50 VA)
- Transformer (240 VAC/24 VAC 50 VA)
- Flushometer Electrical Box Positioning and Support Kit

► **Variations**

- DFB Dual Filtered Fixed Bypass Diaphragm (0.5 gpf ONLY) Code No: 3782691
- OR - Override Button

► **Fixtures**

Consult factory for matching Sloan brand fixture options.

► **Control Circuit**

- Solid State
- 8 Second Arming Delay
- 24 VAC Input
- 24 VAC Output

► **Solenoid Operator**

24 VAC, 50/60 Hz

► **Transformers**

Sloan Part #EL-154 120 VAC, 50/60 Hz Primary 24 VAC, 50/60 Hz Secondary Class II, UL Listed, 50 VA.

Sloan Part #EL-342 240 VAC, 50/60 Hz Primary 24 VAC, 50/60 Hz Secondary Class II, UL Listed, 50 VA.

► **Accessories (Sold Separately)**

See Accessories Section and OPTIMA® Accessories Section of the Sloan catalog for details on these and other OPTIMA® Flushometer variations.

► **Sensor Range**

Nominal 12" - 32" (305 mm - 813 mm) Self-adaptive Window: ± 10" (254 mm)

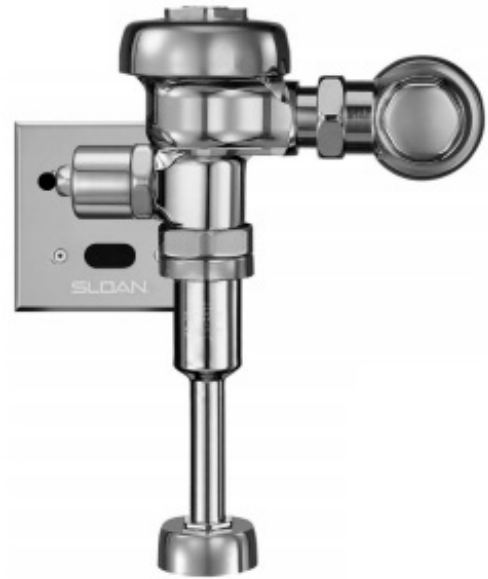

► **Automatic Operation**

Sloan OPTIMA® equipped Flushometers provide the ultimate in sanitary protection and automatic operation. There are no handles to trip or buttons to push. The Flushometer operates by means of an infrared sensor that adapts to its surrounding. Once the user enters the sensor's effective range and then steps away, the Flushometer Solenoid initiates the flushing cycle to flush the fixture.

► **Hygienic**

User makes no physical contact with the Flushometer surface except to initiate the Override Button when required. Helps control the spread of infectious diseases.

► **Economical**

Automatic operation provides water usage savings over other flushing devices. Reduces maintenance and operation costs.

► **Practical**

Solid state electronic circuitry assures years of dependable, trouble-free operation. The operational components of the Flushometer are identical to a handle activated Sloan® Flushometer, proven by over 100 years of experience.

► **Compliance & Certifications**



This space for Architect/Engineer Approval

► **ROUGH-IN**

### ► OPERATION

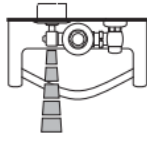

1. A continuous, invisible light beam is emitted from the OPTIMA Sensor.

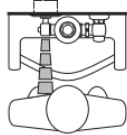

2. As the user enters the beam's effective range (15" to 30") the beam is reflected into the OPTIMA Scanner Window and transformed into a low voltage electrical circuit. Once activated, the Output Circuit continues in a "hold" mode for as long as the user remains within the effective range of the Sensor.

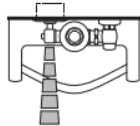

3. When the user steps away from the OPTIMA Sensor, the circuit immediately initiates an electrical "one-time" signal that operates the Solenoid. This initiates the flushing cycle to flush the fixture. The Circuit then automatically resets and is ready for the next user.

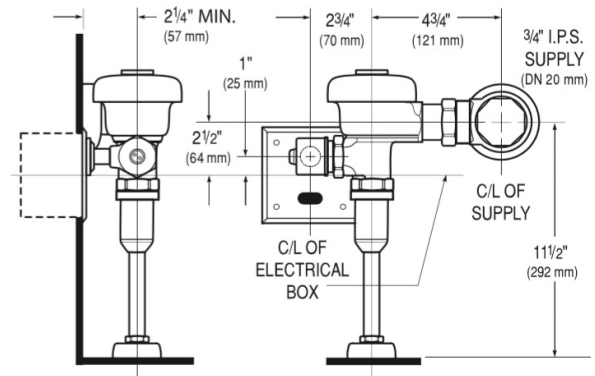

### ► ELECTRICAL BOX INSTALLATION

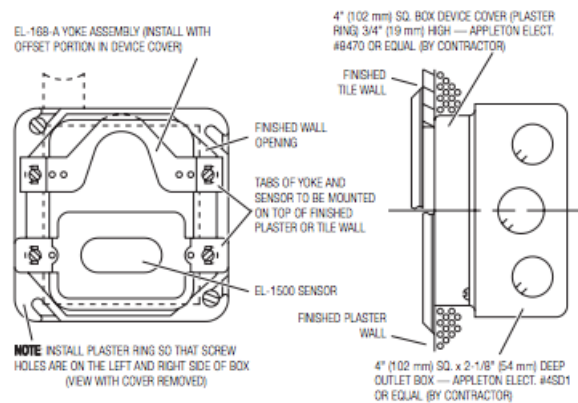

Failure to properly position the electrical boxes to the plumbing rough-in will result in improper installation and impair product performance. All tradesmen (plumbers, electricians, tile setters, etc.) involved with the installation of this product must coordinate their work to assure proper product installation. Installation Template furnished with Flushometer.

To ensure a perfect rough-in, Sloan recommends the use of the EL-485-A Flushometer Electrical Box Positioning and Support Kit. Specify and order the EL 485-A Kit separately. Consult factory for installation details.

### ► WIRING DIAGRAM

One Transformer serves up to ten (10) OPTIMA Closet/ Urinal Flushometers. Specify number of transformers required accordingly.